

# EZP1 Stainless Steel Precleaner with White ConShear™ Blade

## Simple, Quick and Effective for Corrosive Environments

The EZP1 Precleaner is not your average solid-blade belt cleaner that mounts on the head pulley. It features a unique uni-blade design that combines simple, do-it-yourself installation, quick maintenance, and effective cleaning results with the added advantage of corrosion-resistant stainless steel components.

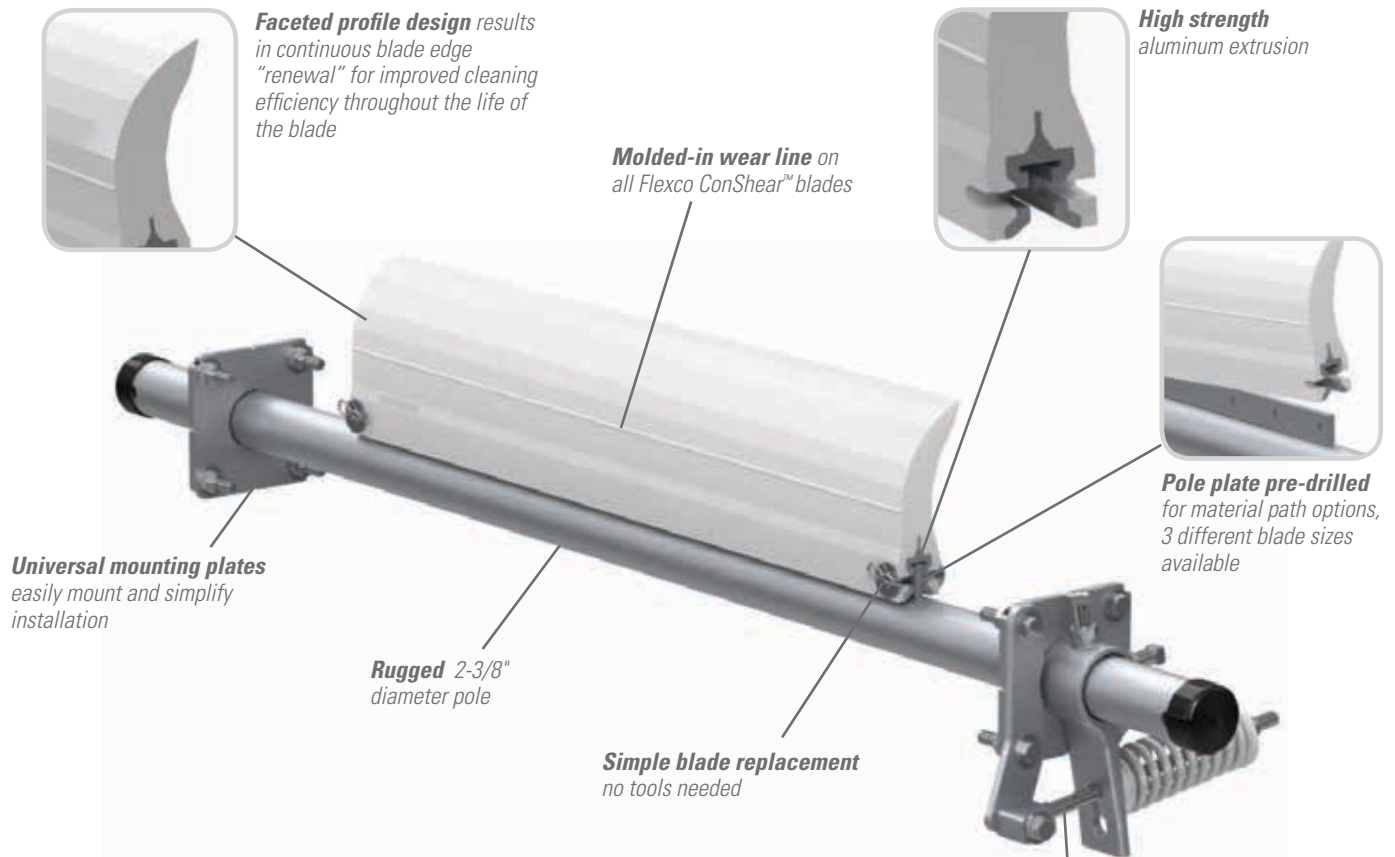

### Features and Benefits

- **White food-grade ConShear™ Precleaner** is chemical resistant, and all ingredients used in urethane formulation comply with the relevant requirements of 21 CFR (FDA Code of Federal Regulations) for use in repeated bulk dry food applications.
- **Stainless Steel.** Corrosive environments wear on any component, but stainless steel can protect against this.
- **Works with Flexco mechanical splices.** The spring tensioner allows the blade to quickly move away from the belt when a splice passes. The polyurethane blade material easily glides over the splice without damage and with minimal cleaning disruption.
- **Compact, streamlined design.** The Stainless Steel EZP1 Precleaner requires only 4" (100 mm) of horizontal clearance for correct installation. Its streamlined contours prevent material buildup on the blade or the pole.
- **Can be used on reversing belts.** Installing cleaners on both pulleys gives superior cleaning results on belts that run in both directions.
- **Fits most conveyor structures.** Available for belt widths from 12" to 72" (300-1800 mm).

**Self-contained spring tensioner**  
allows for measurable  
and verifiable tension.

# EZP1 Stainless Steel Precleaner with White ConShear™ Blade

## Specifications and Guidelines

- **Maximum Belt Speed**  
700 FPM (3.5 M/sec)
- **Temperature Rating**  
-30°F to 180°F (-35°C to 82°C)
- **Minimum Pulley Diameter**  
10" (250 mm)
- **Blade Height**  
7-1/4" (185 mm)
- **Usable Blade Wear Length**  
4" (100 mm)
- **Blade Material**  
Urethane 83 durometer  
Chemical resistant/food grade\*
- **Available for Belt Widths**  
12" to 72" (300 to 1800 mm)
- **Horizontal Clearance Required**  
4" (100 mm)
- **Vertical Clearance Required**  
9-1/2" (238 mm)
- **Pole Length**  
Cleaner size up to 48" (1200mm) + 30" (750mm)  
Cleaner size over 48" (1200mm) + 34" (850mm)
- **Maximum Conveyor Span**  
Cleaner size up to 48" (1200mm) + 25" (625mm)  
Cleaner size over 48" (1200mm) + 29" (725mm)

\* All ingredients used in urethane formulation comply with the relevant requirements of 21 CFR (FDA Code of Federal Regulations) for use in repeated bulk dry food applications.

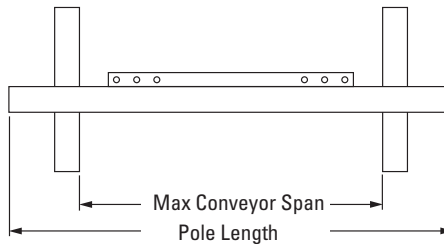

### Pole Location Specs

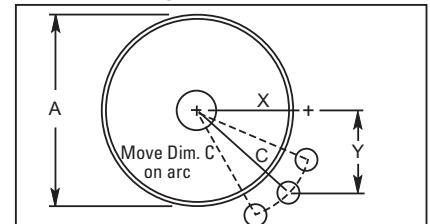

A = Pulley Diameter + Lagging and Belt  
C = Critical Spec to move location if necessary

### Pole Location Chart - Imperial

A	X	Y	C
10"	3"	9"	9-1/2"
12"	4-3/8"	9"	10"
14"	5-7/8"	9"	10-3/4"
16"	7-1/8"	9"	11-1/2"
18"	8-1/4"	9"	12-1/4"
20"	9-3/8"	9"	13"
22"	10-3/4"	9"	14"
24"	12"	9"	15"
26"	13-1/4"	9"	16"
28"	14-3/8"	9"	17"
30"	15-5/8"	9"	18"
32"	16-3/4"	9"	19"
34"	17-7/8"	9"	20"
36"	19"	9"	21"

## Ordering Information

EZP1 S/S Precleaners Belt Width - 2" (50mm) White Blade					
Belt Width		Blade Coverage		Ordering Number	Item Code
in.	mm	in.	mm		
12	300	10	250	CFG-212	78838
18	450	16	400	CFG-218	78839
24	600	22	550	CFG-224	78840
30	750	28	700	CFG-230	78841
36	900	34	850	CFG-236	78842
42	1050	40	1000	CFG-242	78843
48	1200	46	1150	CFG-248	78844
54	1350	52	1300	CFG-254	78845
60	1500	58	1450	CFG-260	78846
72	1800	70	1750	CFG-272	78847

EZP1 S/S Precleaners Belt Width - 8" (200mm) White Blade					
Belt Width		Blade Coverage		Ordering Number	Item Code
in.	mm	in.	mm		
12	300	-	-	N/A	N/A
18	450	10	250	CFG-818	78924
24	600	16	400	CFG-824	78925
30	750	22	550	CFG-830	78926
36	900	28	700	CFG-836	78927
42	1050	34	850	CFG-842	78928
48	1200	40	1000	CFG-848	78929
54	1350	46	1150	CFG-854	78930
60	1500	52	1300	CFG-860	78931
72	1800	64	1600	CFG-872	78932

EZP1 Mild Steel Precleaners Belt Width - 2" (50mm) White Blade					
Belt Width		Blade Coverage		Ordering Number	Item Code
in.	mm	in.	mm		
12	300	10	250	EZP1-212W	78934
18	450	16	400	EZP1-218W	78935
24	600	22	550	EZP1-224W	78936
30	750	28	700	EZP1-230W	78937
36	900	34	850	EZP1-236W	78938
42	1050	40	1000	EZP1-242W	78939
48	1200	46	1150	EZP1-248W	78940
54	1350	52	1300	EZP1-254W	78941
60	1500	58	1450	EZP1-260W	78942
72	1800	70	1750	EZP1-272W	78943

ConShear™ White Replacement Blades			
Blade Width		Ordering Number	Item Code
in.	mm		
10	250	CRB-W10	78471
16	400	CRB-W16	78472
22	550	CRB-W22	78473
28	700	CRB-W28	78474
34	850	CRB-W34	78475
40	1000	CRB-W40	78476
46	1150	CRB-W46	78477
52	1300	CRB-W52	78478
58	1450	CRB-W58	78479
64	1600	CRB-W64	78480
70	1750	CRB-W70	78481

### Pole Location Chart - Metric

A	X	Y	C
250	74	230	242
300	108	230	254
350	146	230	273
400	179	230	291
450	207	230	309
500	235	230	329
550	266	230	352
600	299	230	377
650	330	230	402
700	360	230	427
750	389	230	452
800	417	230	477
850	446	230	501
900	474	230	526

Authorized Distributor:



2525 Wisconsin Avenue • Downers Grove, IL 60515-4200 • USA  
Tel: (630) 971-0150 • Fax: (630) 971-1180 • E-mail: info@flexco.com

Visit [www.flexco.com](http://www.flexco.com) for other Flexco locations and products.

©2014 Flexible Steel Lacing Company. 09/14. For reorder: X2667

